

Light Reflection

Read from **Lesson 1** of the **Reflection** chapter at **The Physics Classroom**:

<http://www.physicsclassroom.com/Class/refln/u1311a.html>
<http://www.physicsclassroom.com/Class/refln/u1311b.html>
<http://www.physicsclassroom.com/Class/refln/u1311c.html>

MOP Connection: Reflection and Mirrors: sublevel 1

- Place a letter in the blank in order to classify the following objects as being either luminous (L) or illuminated (I) objects.
 _____ Sun _____ Moon _____ Person
 _____ Whiteboard _____ Light bulb _____ Candle
- These diagrams are intended to represent the path of light from an object to an eye as the eye sights at the image of the object. Each diagram is incorrect. Discuss what makes them incorrect.

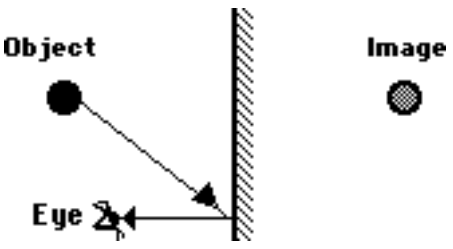
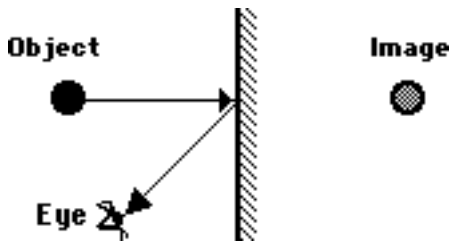
<p>a.</p>  <p>Object Image</p> <p>Eye</p> <p>Discussion: _____ _____ _____</p>	<p>b.</p>  <p>Object Image</p> <p>Eye</p> <p>Discussion: _____ _____ _____</p>
--	---

- State the law of reflection in the space below.

Consider the diagram at the right in answering the next three questions.

- The angle of incidence is denoted by angle ____.
- The angle of reflection is denoted by angle ____.
- If an incident ray of light makes an angle of 35° with the mirror surface then the angle of reflection is _____ $^\circ$.

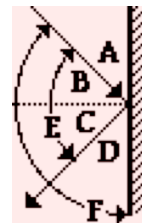

- Why do windows of distant houses appear to reflect the sun only when rising or setting? Explain in words. Use the diagram to help, drawing appropriate light rays on the diagram.

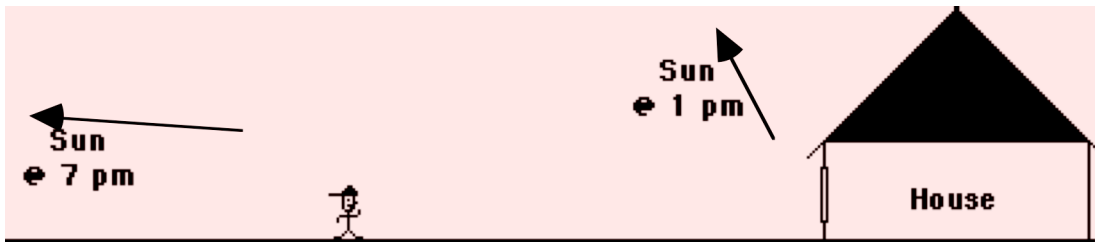

Light, Reflection and Mirrors

8. Use the law of reflection and the *embedded* protractor in order to draw the reflected ray associated with the given incident ray for the following plane mirror situations. (Markings are provided at 15° increments.)

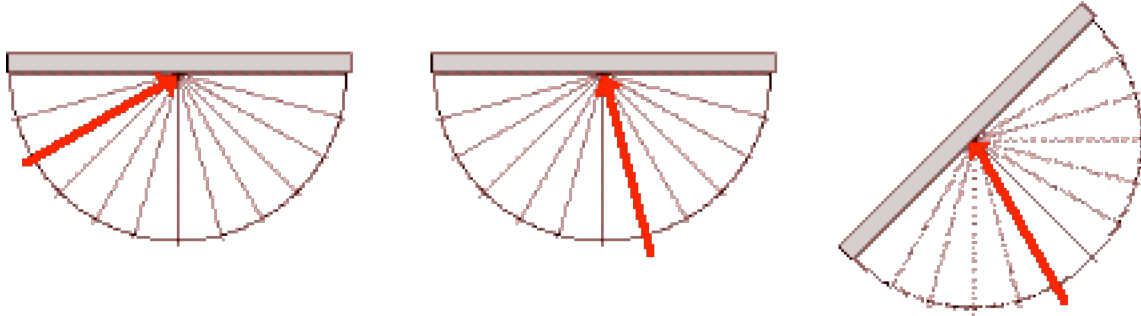

9. Now for a research question:

In this unit we will often discuss how the reflection of light from a mirror results in the formation of an image. The term **image** as used here has an obvious context - physics. But the term image has numerous other contexts - psychology (a positive self-*image*), religion (created in God's *image*), business (the company's *image*), medicine (an x-ray *image*), etc.

Your research question involves finding a dictionary and looking up the definition of the word **image**. Write down several meaningful definitions from several contexts in the spaces below. (If you do not have a dictionary at home then you can use dictionary.com or wikipedia.org)

- a. _____

- b. _____

- c. _____

- d. _____

- e. _____

10. Now write in your own words a personal definition of what you believe an image of an object is:

Specular (Regular) versus Diffuse Reflection

Read from **Lesson 1** of the **Reflection** chapter at **The Physics Classroom**:

<http://www.physicsclassroom.com/Class/refln/u1311d.html>

MOP Connection: Reflection and Mirrors: sublevel 4

1. Describe the difference between diffuse reflection and regular (or specular) reflection.

2. Explain what causes light rays to undergo diffuse reflection.

3. Which one of the following diagrams depicts diffuse reflection? _____

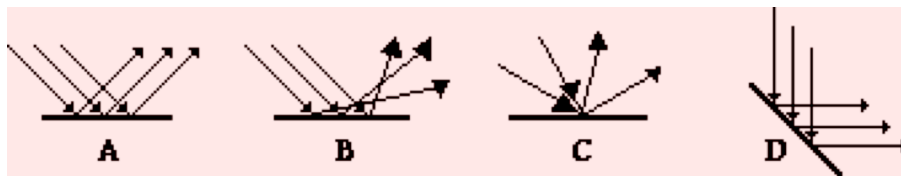

4. **True or False:**

When a beam of light undergoes diffuse reflection, individual rays within the beam do NOT follow the law of reflection.

Explain your answer.

5. For each of the five surfaces given below, draw normal lines.

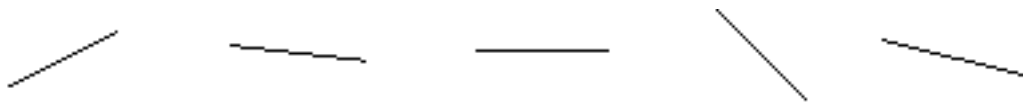

6. Consider the diagram at the right of five rays of light approaching a microscopically rough surface. For each incident ray, estimate the normal line and draw the corresponding reflected ray of light.

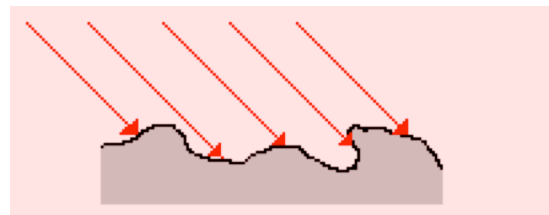

Light, Reflection and Mirrors

7. Identify whether the following phenomenon are attributable to diffuse reflection (DR) or regular reflection (RR):
- The image of a mountain can be clearly seen in the calm waters of a lake. _____
 - A lacquered tabletop produces a glare of the lamp bulb in the overhead light. _____
 - Water is sprayed onto a sheet of paper. A laser beam is directed towards the paper, reflects and produces a red dot on the ceiling. _____
 - Light from the overhead lights strikes your body and reflects towards all your classmate's eyes. _____
8. A microscopic view of a sheet of paper is shown in the diagram at the right. Would you expect this sheet of paper to cause light to undergo regular or diffuse reflection? _____ Explain.



A microscopic view of a sheet of paper.

9. From what type of surface do you think it would be easier to read? From pages which are rough or from pages which are smooth and glossy? _____ Explain your answer.

10. Driving at night offers a great example of diffuse vs. regular reflection. A dry road is a diffuse reflector, while a wet road is not. On the diagrams below, sketch the reflected light off a wet and dry surface.

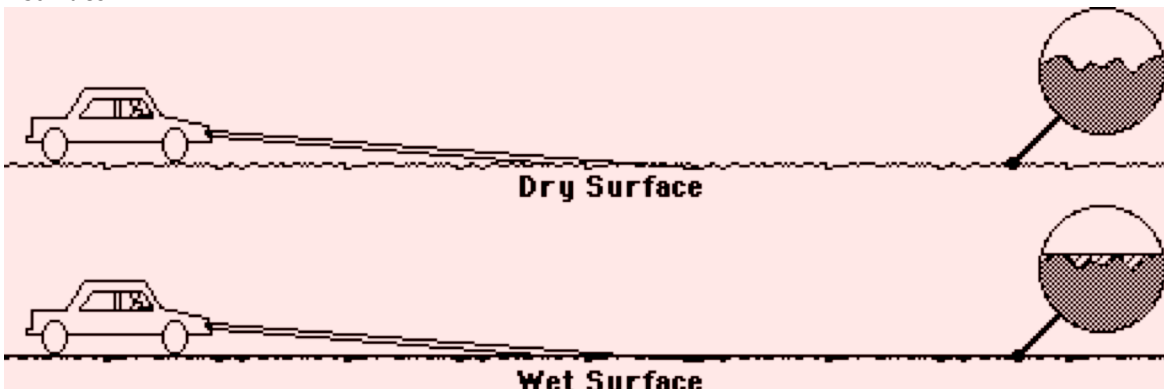

Why would the wet road appear to the driver to be darker than the dry road?

11. The diagram below contrasts the reflection of light off a smooth surface (left) with the reflection of light off a rough surface (right). Compare the two diagrams and explain why the reflected rays for a rough surface do not result in the formation of an image.



Image Formation and Characteristics

Read from **Lesson 2** of the **Reflection** chapter at **The Physics Classroom**:

<http://www.physicsclassroom.com/Class/refln/u1312a.html>

<http://www.physicsclassroom.com/Class/refln/u1312b.html>

<http://www.physicsclassroom.com/Class/refln/u1312c.html>

MOP Connection: Reflection and Mirrors: sublevel 2

1. An object (denoted by a dark circle) is placed in front of a plane mirror as shown below. Light from the object emanates in a variety of directions. For each light ray incident to the mirror, accurately draw the corresponding reflected ray. Use a protractor, straight-edge, and the law of reflection.

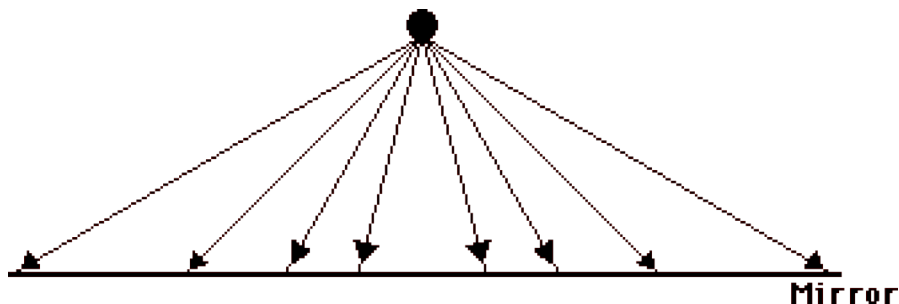

2. For each reflected ray drawn in the diagram above, use dashed lines to trace the reflected ray backwards behind the mirror. If done correctly, all reflected rays should intersect at the same location; this location corresponds to the image location.
3. Make measurements on the diagram to compare the object distance (distance from the object to the mirror) to the image distance (distance from the intersection point or image location to the mirror). Record the results of your comparison in the space below.

Light, Reflection and Mirrors

4. The image of an object as formed by a plane mirror is located ____.
- on the mirror surface
 - in front of the mirror surface
 - behind the mirror surface
 - any of the above, depending on the object's location.
5. Which of the following statements are true of plane mirror images? List all that apply in alphabetical order with no spaces between letters.
- The location of an image is different for different observers.
 - Observers at different locations will sight along different lines at the same image.
 - Every image is located on the mirror surface and at the same location for different observers.
 - Every image is located on the mirror surface, but at a different location for different observers.
 - All observers (regardless of their location) will sight at the same image location.
6. The diagram below depicts the path of four incident rays emerging from an object and approaching a mirror. Five lettered locations are shown on the opposite side of the mirror. Which location is representative of the image location?

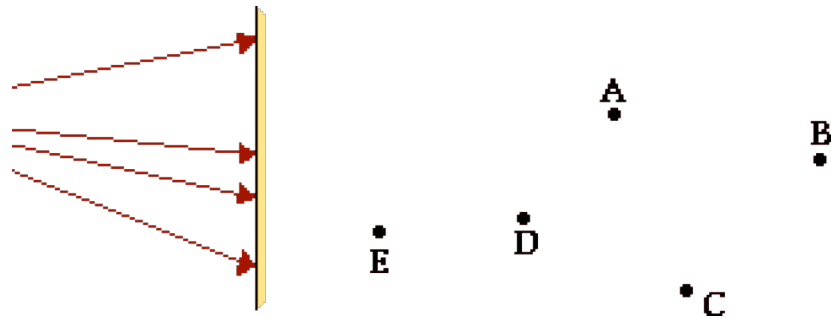

7. The diagram below depicts the path of four reflected rays which originated at the object on the left side of the mirror and have subsequently reflected from the mirror. Five lettered locations are shown on the right side of the mirror. Which location is representative of the image location?

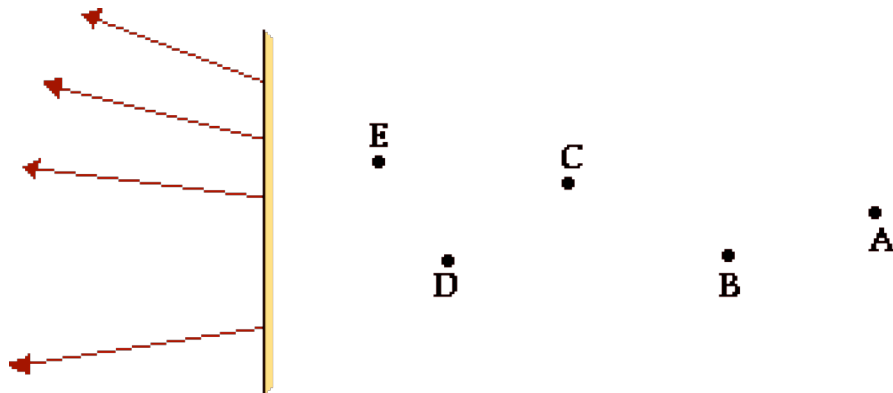

Ray Diagrams

Read from **Lesson 2** of the **Reflection** chapter at **The Physics Classroom**:

<http://www.physicsclassroom.com/Class/refln/u13l2d.html>

MOP Connection: Reflection and Mirrors: sublevel 3

Four Steps to Drawing Ray Diagrams

Plane mirror ray diagrams show how light travels from an object to the mirror to an eye in order for the eye to view the image of the object. There are four steps to the construction of a ray diagram.

- i. Draw the image of the object.
- ii. Pick one extreme on the image of the object and draw the reflected ray which will travel to the eye as the eye sights at this point.
- iii. Draw the incident ray for light traveling from the corresponding extreme on the object to the mirror.
- iv. Repeat steps ii and iii for all other extremities on the object.

Locating Images

1. Locate all of the images for the following objects (labeled "o") as produced by the mirror (labeled "m"). Consider steps 1 and 2 above.

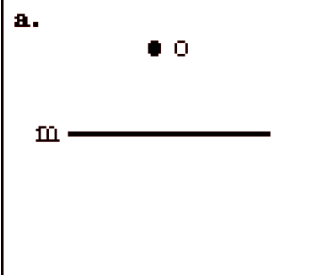
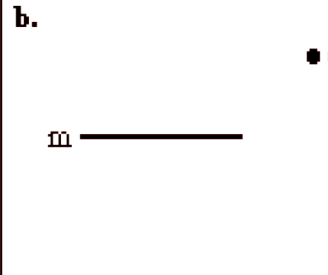
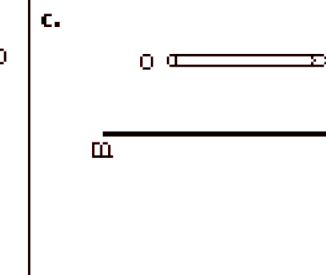
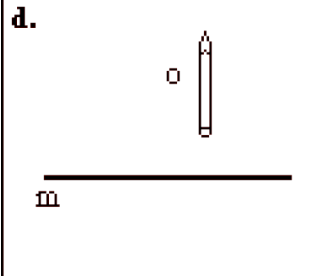
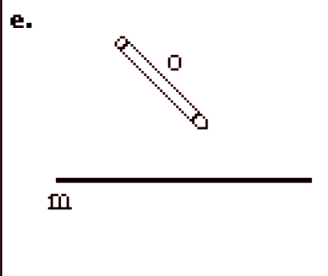
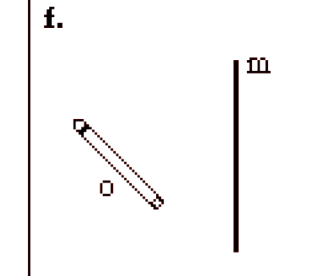
<p>a.</p> 	<p>b.</p> 	<p>c.</p> 
<p>d.</p> 	<p>e.</p> 	<p>f.</p> 

Light, Reflection and Mirrors

Drawing Ray Diagrams

Questions #2 - #11 provide a detailed procedure for the completion of a ray diagram.

The diagram at the right shows an arrow (the object), a plane mirror, and an eye. Use this diagram and a ruler/straight edge to do the following steps.

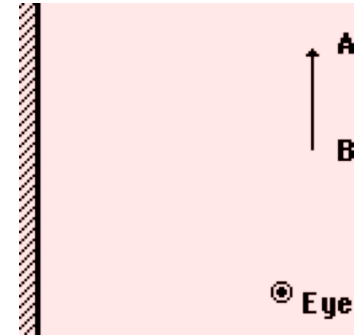

2. Locate the image of points A and B. Label these points as A' and B'.
3. Draw in the complete image. Compare the size of the image to the size of the object.
4. If the eye is to see A by looking in the mirror, then the eye must sight along a line at the image of A (i.e., A'). Draw the reflected ray which reaches the eye as it sights at A'. Use a solid line and an arrowhead.
5. Extend this reflected ray beyond the mirror using a dashed line to show that the eye is sighting along a line directly at A'.
6. The light which follows the path shown by the reflected ray originated from point A. Show this by accurately drawing the incident ray which starts at point A and approaches the mirror. Be sure to use a solid line and put an arrow upon the ray.
7. Repeat steps #4-#6 in order to show how light travels from point B to the mirror and reflects towards the eye as the eye sights along a line at B'.
8. On the diagram, label the point on the mirror where the incident ray from A reflects from the mirror with the letter "x".
9. On the diagram, label the point on the mirror where the incident ray from B reflects from the mirror with the letter "y".
10. Points "x" and "y" represent the points on the mirror which would be needed to view point A and point B on the object. Where will any other ray from the object reflect from the mirror before traveling to the eye?
11. What parts of the mirror could be removed without interfering with the eye's ability to see the entire image of the arrow? Circle these sections of the mirror.

-
12. For the following *objects*, (a) draw the corresponding *images*, and (b) draw and label the incident and reflected rays which would allow the eye to view the object in the mirror (labeled "m").

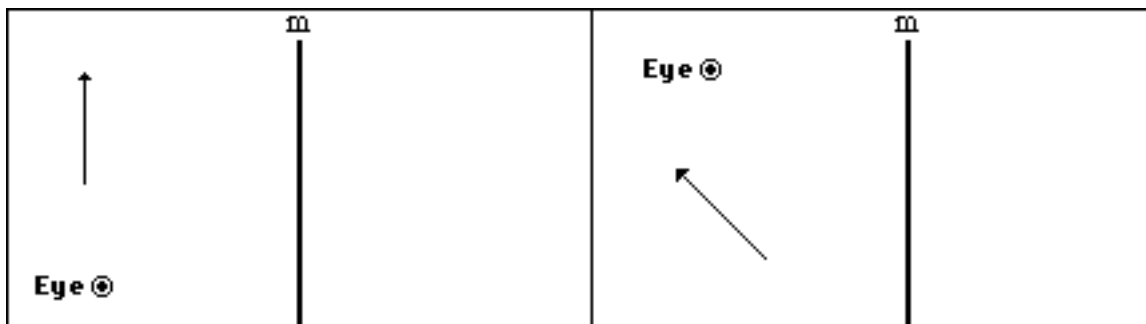

Light, Reflection and Mirrors

15. Consider the mirror and the stick-person shown in the two diagrams below. The distance between the mirror and the person is different in the two diagrams. For each diagram, accurately draw and label the image of the stick-person in the appropriate position. Finally, draw lines of sight from the eyes of the stick-person to the mirror in order to indicate which portion of the mirror is needed to view the image. Use a ruler/straight-edge and be precise.

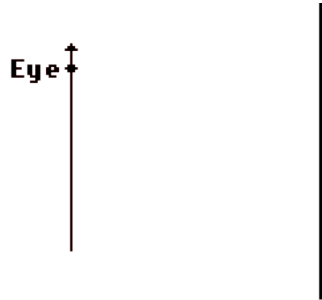

16. Compare the height of the stick-person to the length of mirror needed to view the stick-person. Make some measurements (from the diagram above) and record below.
17. Does the distance from the stick-person to the mirror seem to effect the amount of mirror which the person needs to view the image? _____ Explain and support your answer using numerical values taken from question #15 above.

Curved Mirrors and The Law of Reflection

Read from **Lesson 3** of the **Reflection** chapter at **The Physics Classroom**:

<http://www.physicsclassroom.com/Class/refln/u13l3a.html>

MOP Connection: Reflection and Mirrors: sublevel 5

The diagram below depicts a **concave mirror** with its principal axis and its center of curvature (C). Five incident rays are shown traveling parallel to the principal axis.

1. Construct normal lines for each of the five incident rays. (Geometry Review: A line which passes through the center of a circle will be perpendicular to the circle at its point of intersection. Thus, the normal line for each of these incident rays passes through C.)
2. Measure the angle of incidence and use the law of reflection to construct five reflected rays at the appropriate angle of reflection.
3. Construct two more incident rays parallel to the principal axis that strike points 6 and 7. Draw the normal line and use the law of reflection to draw the corresponding reflected rays.

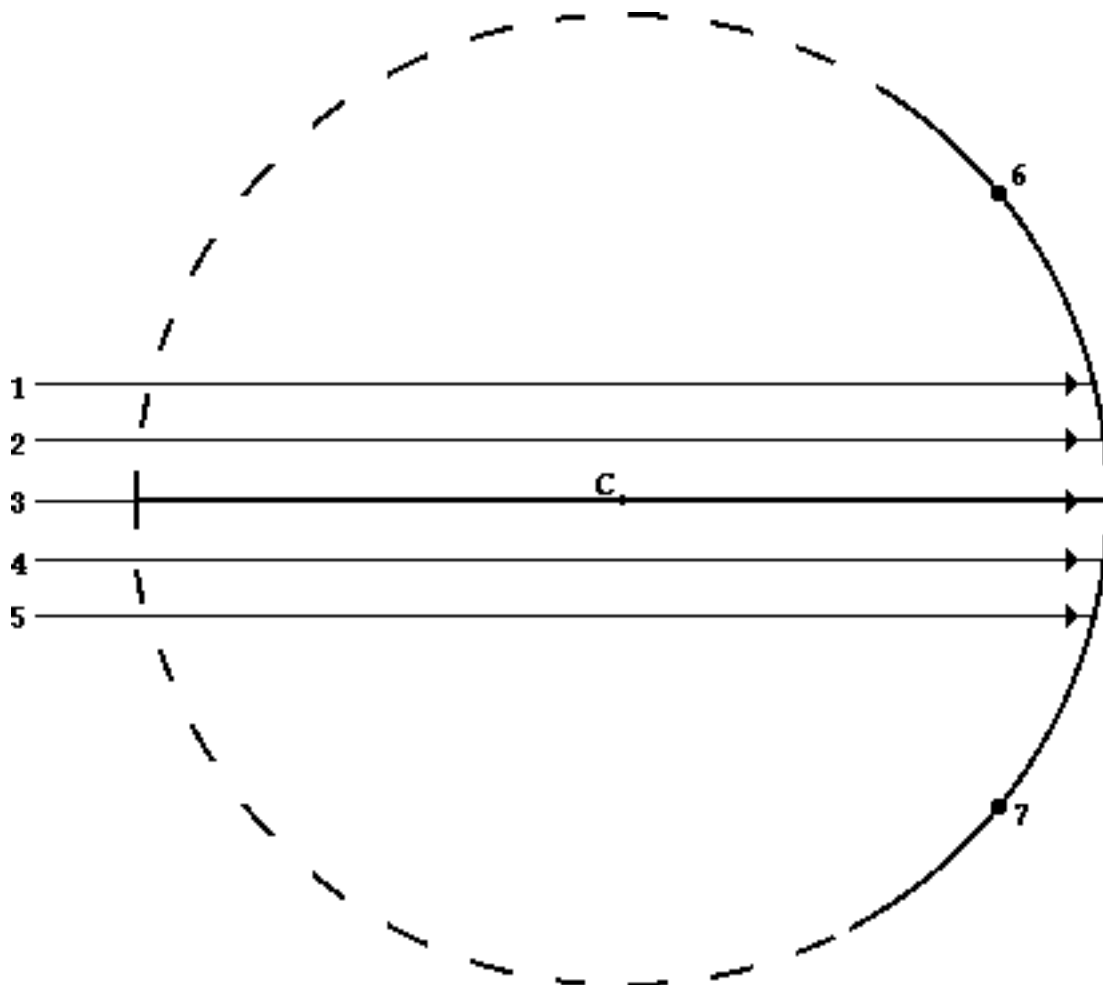

4. Label the **focal point (F)** on the diagram above.
5. Propose your personal definition of the focal point: The focal point is ...
6. Make some generalized statements about rays 1-5 and about rays 6-7. How are they similar and how are they different?

Light, Reflection and Mirrors

The diagram below depicts a **convex mirror** with its principal axis and its center of curvature (**C**). Five incident rays moving parallel to the principal axis are shown.

7. As on the front side, construct normal lines for each of the five incident rays. (Geometry Review: A line which passes through the center of a circle will be perpendicular to the circle at its point of intersection. Thus, the normal line for each of these incident rays passes through **C**.)
8. Measure the angle of incidence and use the law of reflection to construct five reflected rays at the appropriate angle of reflection.
9. For each reflected ray, construct extensions of the rays backwards behind the mirror until they intersect the principal axis.

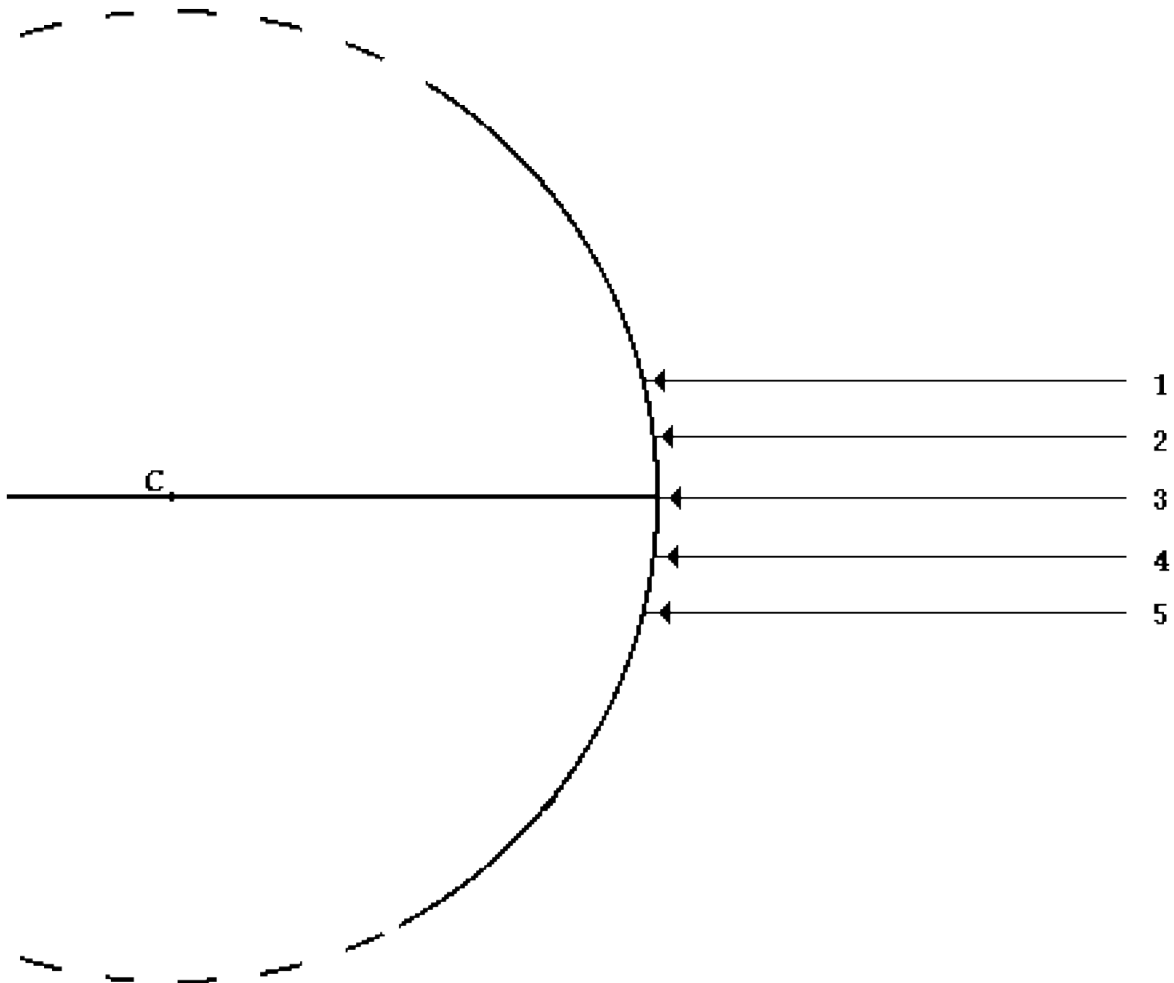

10. Make some generalized statements about rays 1-5 to describe how they reflect.

Conclusion:

Propose a rule of reflection for both concave and convex mirrors which would describe how incident rays parallel to the principal axis would behave upon reflection.

Spherical Mirrors

Read from **Lesson 3** of the **Reflection** chapter at **The Physics Classroom**:

<http://www.physicsclassroom.com/Class/refln/u13l3a.html>

<http://www.physicsclassroom.com/Class/refln/u13l3b.html>

<http://www.physicsclassroom.com/Class/refln/u13l3c.html>

MOP Connection: Reflection and Mirrors: sublevel 5

- A spherical mirror has a shape which is a section of a sphere. Consider the concave spherical mirror shown at the right. Label the following on the diagram:
 - the principal axis (a line) as **PA**
 - the focal point (a point) as **F**
 - the center of curvature (a point) as **C**
 - the focal length (a length) as **f**
 - the radius of curvature (a length) as **R**
- Explain why concave mirrors are sometimes called converging mirrors.

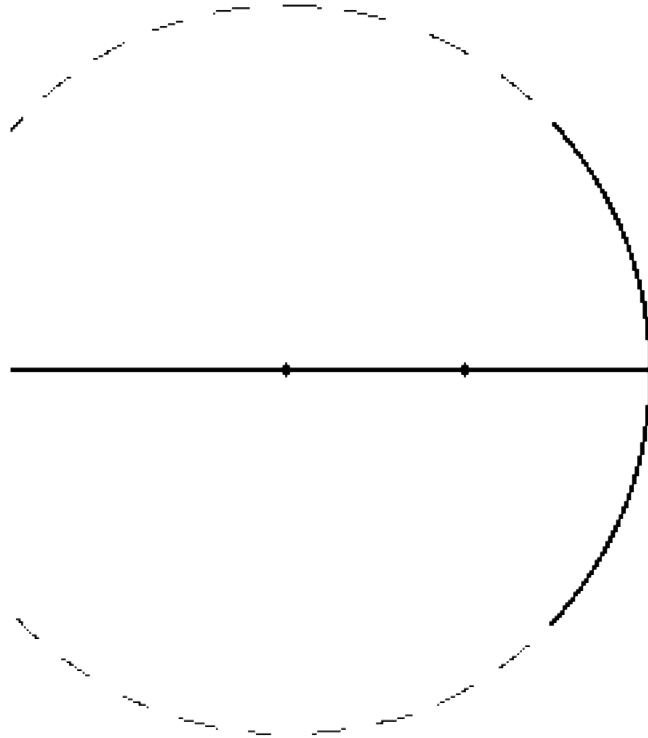

- Explain why convex mirrors are sometimes called diverging mirrors.
- The diagrams below show three incident rays. For each diagram, draw the three corresponding reflected rays on the diagrams. Place arrowheads upon all your rays. (Study the ray diagrams in your textbook carefully to answer these questions.)

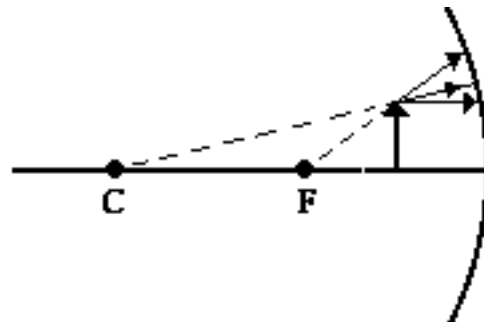
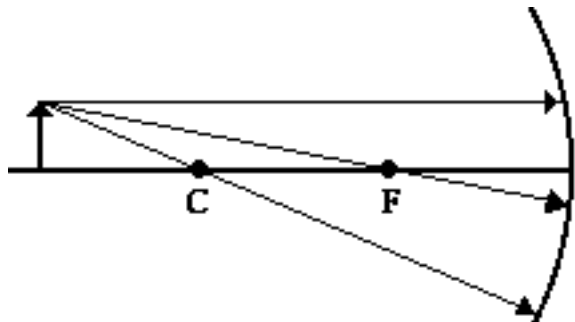

Light, Reflection and Mirrors

5. State the three rules which describe the predictable reflection of three rays of incident light for a concave mirror. (See question #4.)
6. Light from a distant star is collected by a concave mirror. How far from the mirror do the light rays converge if the radius of curvature of the mirror is 150 cm?
7. Suppose your teacher gives you a concave mirror and asks you to find the focal point. Describe the procedure you would use to do this.

8. The image location is the location in space from where it would seem to every observer as though reflected light is coming from. The diagram at the right shows an object and a concave mirror. Four rays of light from the object approach the mirror. Note that ray 1 and ray 4 are two of the three *principal rays* whose behavior are described in question #5 above. Reflect each ray (starting with rays 1 and 4) and determine the image location. Put a dot at the image location and label it image.

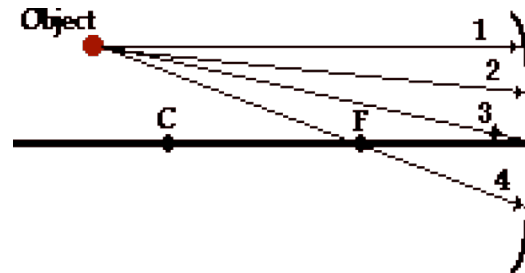

9. Consider the diagram at the right of an object, an image, and a concave mirror. On the diagram, show the path of light from object to the mirror to the eye as the eye sights at the image.

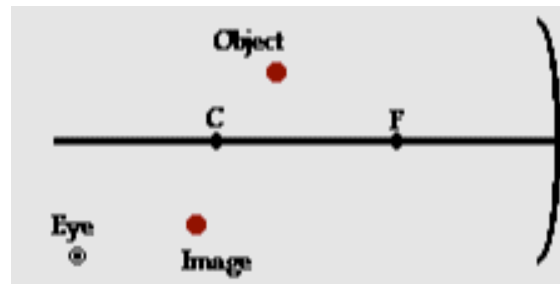

Ray Diagrams for Concave Mirrors

Read from **Lesson 3** of the **Reflection** chapter at **The Physics Classroom**:

<http://www.physicsclassroom.com/Class/refln/u13l3d.html>
<http://www.physicsclassroom.com/Class/refln/u13l3e.html>

MOP Connection: Reflection and Mirrors: sublevels 5 and 6

For the following mirrors and corresponding object positions, construct ray diagrams. Then describe the Location of the image, Orientation (upright or inverted) of the image, the relative Size of the image (larger or smaller than object), and the Type of image (real or virtual). For **Case 4**, merely construct the ray diagram.

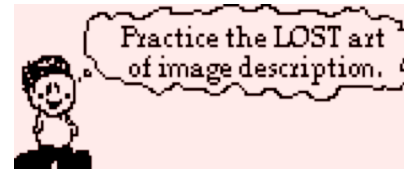

NOTE: 1) All light rays have arrowheads which indicate the direction of travel of the ray.
 2) Always draw in the image once located (an arrow is a good representation).
 3) Exactness counts. Use a straight-edge and be accurate.

Case 1: If the object is located "beyond" the center of curvature.

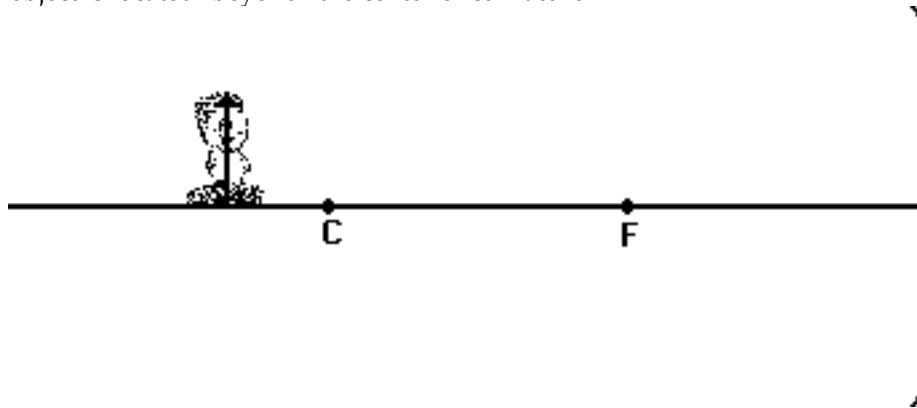

Description of Image:

Location: _____

O: Upright or Inverted S: Magnified or Reduced T: Real or Virtual

Case 2: If the object is located at the center of curvature.

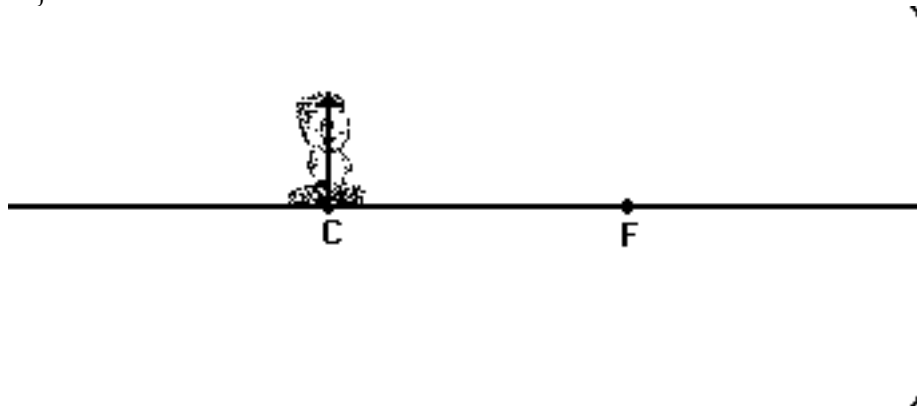

Description of Image:

Location: _____

O: Upright or Inverted S: Magnified or Reduced T: Real or Virtual

Light, Reflection and Mirrors

Case 3: If the object is located between the center of curvature and the focal point.

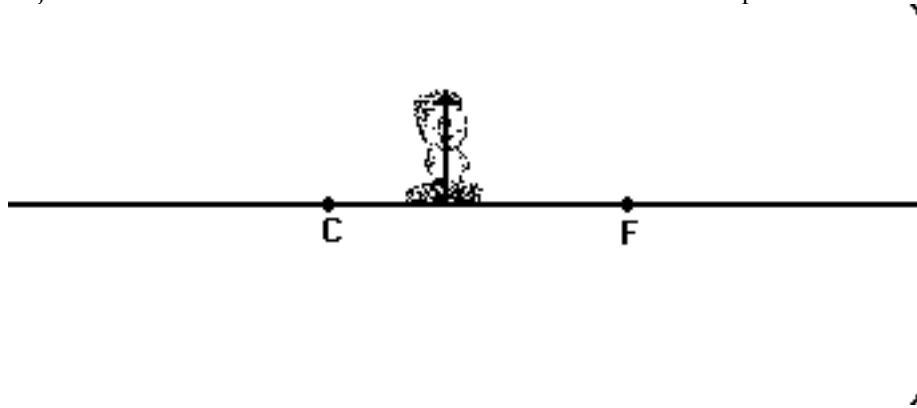

Description of Image:

Location: _____

O: Upright or Inverted

S: Magnified or Reduced

T: Real or Virtual

Case 4: If the object is located at the focal point.

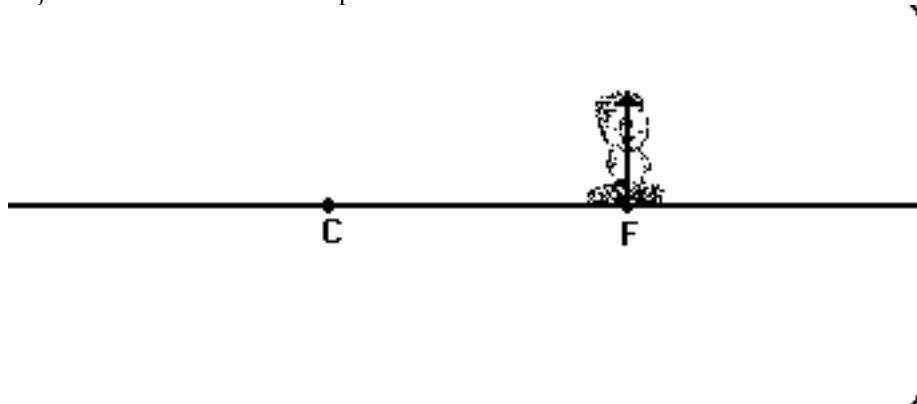

No Description Required

Case 5: If the object is located between the focal point and the mirror.

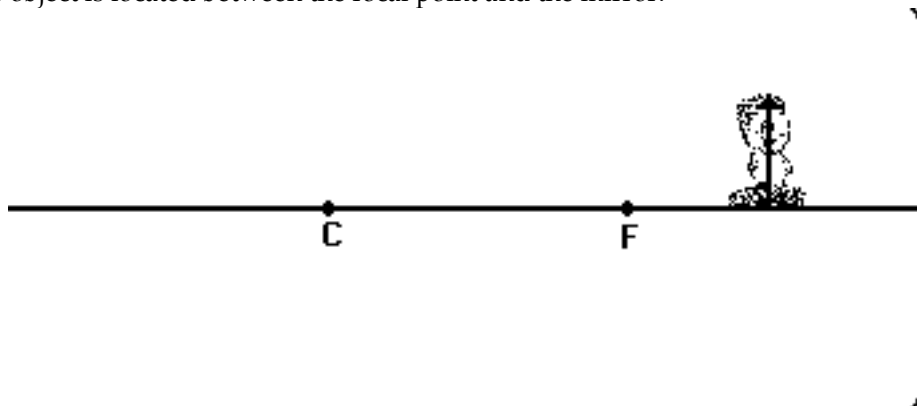

Description of Image:

Location: _____

O: Upright or Inverted

S: Magnified or Reduced

T: Real or Virtual

Ray Diagrams for Convex Mirrors

Read from **Lesson 4** of the **Reflection** chapter at **The Physics Classroom**:

<http://www.physicsclassroom.com/Class/refln/u1314b.html>
<http://www.physicsclassroom.com/Class/refln/u1314c.html>

MOP Connection: Reflection and Mirrors: sublevels 8 and 9

For the following mirrors and corresponding object positions, construct ray diagrams. Then practice the **LOST** art of image description. Identify the **L**ocation of the image, **O**rientation (upright or inverted) of the image, the relative **S**ize of the image (larger or smaller than object), and the **T**ype of image (real or virtual).

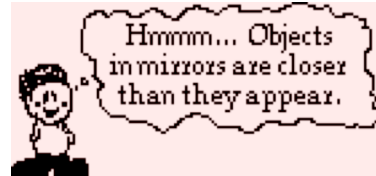

NOTE: 1) All light rays have arrowheads which indicate the direction of travel of the ray.
 2) Always draw in the image once located (an arrow is a good representation).
 3) Exactness counts. Use a straight-edge and be accurate.

Case 1: Object is Relatively Close to Mirror

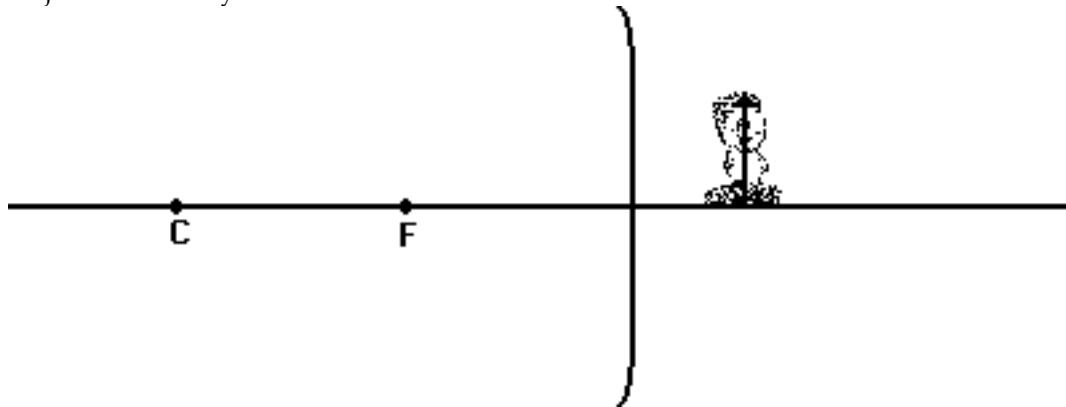

Description of Image:

Location: _____
O: Upright or Inverted **S:** Magnified or Reduced **T:** Real or Virtual

Case 2: Object is Relatively Far Away from Mirror

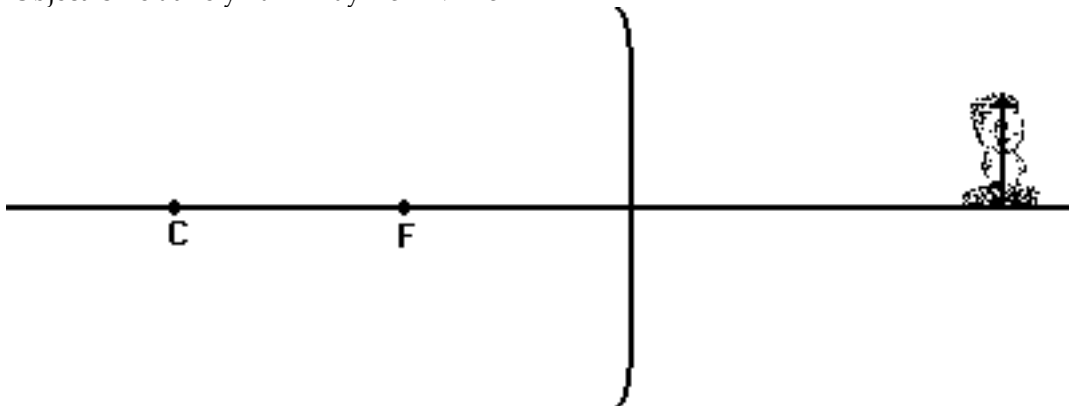

Description of Image:

Location: _____
O: Upright or Inverted **S:** Magnified or Reduced **T:** Real or Virtual

Mathematics of Curved Mirrors

Read from **Lessons 3 and 4** of the **Reflection** chapter at **The Physics Classroom**:

<http://www.physicsclassroom.com/Class/refln/u1313f.html>

<http://www.physicsclassroom.com/Class/refln/u1314d.html>

MOP Connection: Reflection and Mirrors: sublevels 7 and 10

Use the mirror equation and the magnification ratio to solve the following problems. **PSYW**

1. Bobby places a 4.25-cm tall light bulb a distance of 36.2 cm from a concave mirror. If the mirror has a focal length of 19.2 cm, then what is the image height and image distance?
2. Van Itee, quite concerned about the pimple on his chin, is looking into a concave mirror with a focal length of 33.6 cm. Determine the image height and image distance of the 2.50-mm sized pimple when placed 25.2 cm from the mirror.
3. Al Wayscurious is intrigued by the reflective abilities of his family's soup ladle. The ladle acts as a concave mirror with a 2.59-cm focal length. Determine the image size of a Al's 24.8-cm tall face when placed 12.8 cm from the ladle's surface.
4. Mr. H splurged when he bought his Yugo and ordered the side mirror option. The mirror has a focal length of -88.4 cm. What is the image height of a 4.59-meter tall truck when located 12.6 meters away from the mirror?
5. A Christmas tree ornament with a 8.64-cm diameter serves as a convex mirror surface. Determine the image size and the image distance of a 4-foot tall child standing a distance of 2.65 meters away.

Object-Image Relations

Read from **Lesson 3** of the **Reflection** chapter at **The Physics Classroom**:

<http://www.physicsclassroom.com/Class/refln/u13l3d.html>
<http://www.physicsclassroom.com/Class/refln/u13l3e.html>

MOP Connection: Reflection and Mirrors: sublevels 6, 7, 9, 10, 11

- A 10.0-cm tall object is placed in front of a concave mirror with a focal length of 20.0 cm. For each object distance, calculate the image distance, magnification, and image height. Sketch a ray diagram showing the object in the appropriate location and the image with the proper location, orientation and relative size.

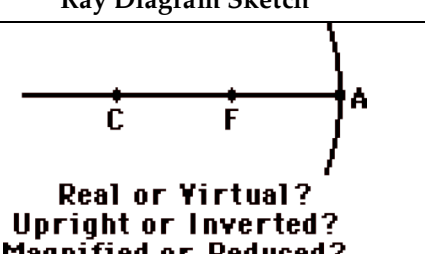
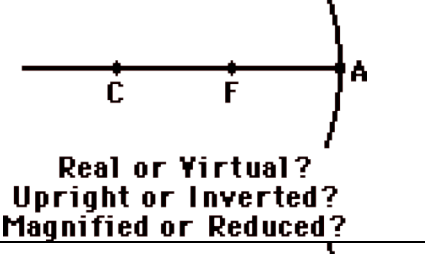
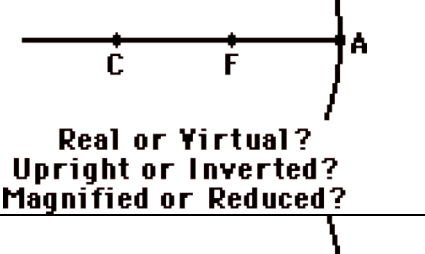
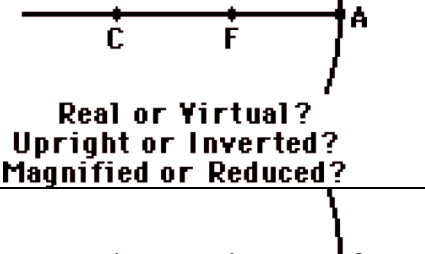
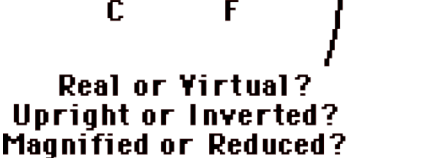
	d_o	d_i	Mag.	h_i	Ray Diagram Sketch
a.	50 cm	_____	_____	_____	 <p>Real or Virtual? Upright or Inverted? Magnified or Reduced?</p>
b.	40 cm	_____	_____	_____	 <p>Real or Virtual? Upright or Inverted? Magnified or Reduced?</p>
c.	30 cm	_____	_____	_____	 <p>Real or Virtual? Upright or Inverted? Magnified or Reduced?</p>
d.	20 cm	_____	_____	_____	 <p>Real or Virtual? Upright or Inverted? Magnified or Reduced?</p>
e.	10 cm	_____	_____	_____	 <p>Real or Virtual? Upright or Inverted? Magnified or Reduced?</p>

Light, Reflection and Mirrors

2. Arrows numbered 1-8 represent object locations for a concave mirror. For each of these objects, use your understanding of image characteristics to determine the corresponding image location, orientation and relative size. Since these diagrams have not been created to scale, do NOT use ray diagrams to determine your answers.

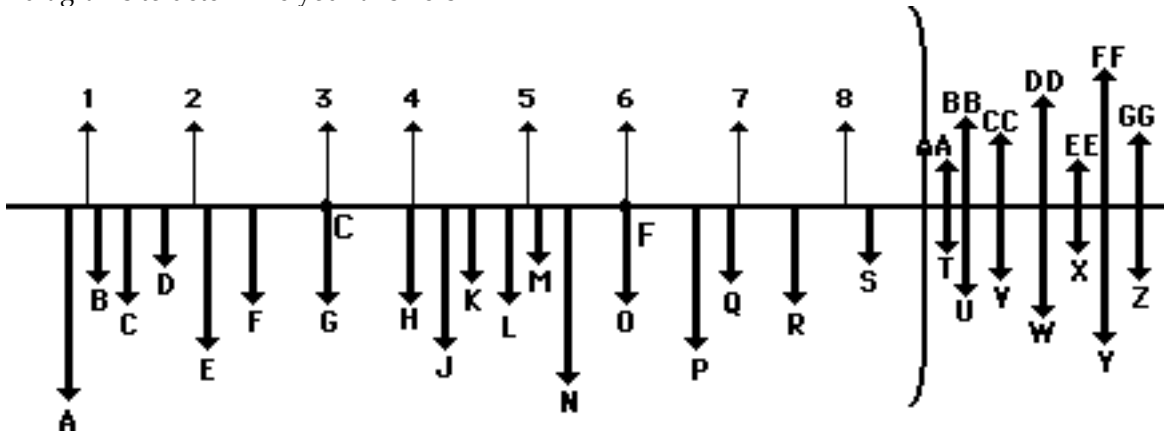

Object	Image
1	
2	
3	
4	

Object	Image
5	
6	
7	
8	

3. Arrows numbered 1-4 represent object locations for a convex mirror. For each of these objects, use your understanding of image characteristics to determine the corresponding image location, orientation and relative size. Since these diagrams have not been created to scale, do NOT use ray diagrams to determine your answers.

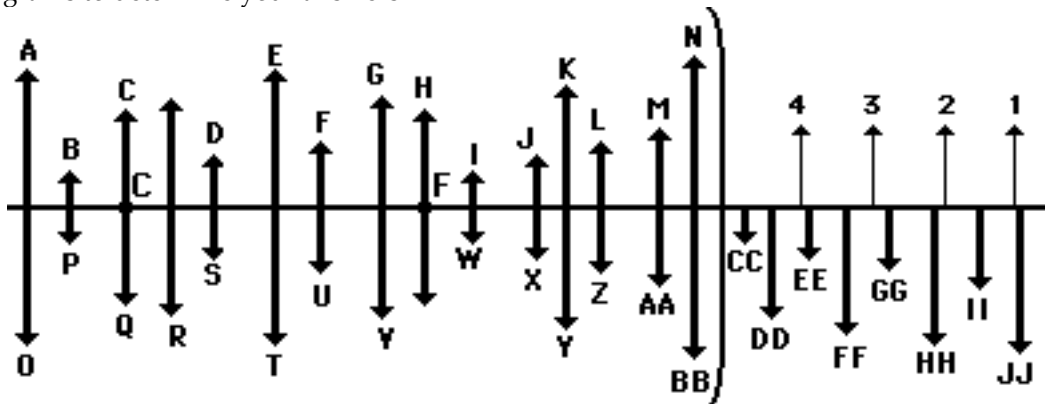

Object	Image
1	
2	

Object	Image
3	
4	